

fully framed

S H O W E R S Y S T E M S



alspec
ALUMINIUM SYSTEMS
SPECIALISTS

 **danmac™**
SHOWER SCREENS AND WARDROBES
POWERED BY ALSPEC

classic

STANDARD PIVOT



The fully framed standard shower system is the traditional, easy to clean, low maintenance option. Although traditional, it has a modern profile with an assortment of colours to choose from. The Danmac fully framed standard shower screen can be custom designed to suit your individual requirements.



Specifications

- Easy to clean, low maintenance design
- Twin lock adjustable pivot system
- Modern profile
- Minimal door clearance to reduce water splash
- Full length captive magnet
- Custom designed to suit your requirements
- Panels are available and can be added to either side of the door to cater for towel rails, vanities, toilet, etc.
- Available in Bright Silver, Matt Natural, Pearl White, Black, Barley and White Birch



Exploded view of Fully Framed Pivot

Custom made to order fully framed, semi-frameless and frameless shower screen kits available, discuss further with your Area Manager.

affinity

FULL OPENING PIVOT



The Affinity fully framed system is patented and manufactured from the highest quality brass, stainless steel pin and nylon insert. The Affinity full opening pivot inserts into the back edge of the door, ensuring a full opening door for all shower screen applications.



Affinity 18 Fully Framed Shower

Specifications

- Patent design no. 146773
- Ideal for tight shower screen openings
- With or without sill
- Wheelchair accessibility
- Larger door opening up to 1000mm wide
- Magnetic closure
- Available in Bright Silver, Matt Natural, Pearl White, Black, Barley and White Birch

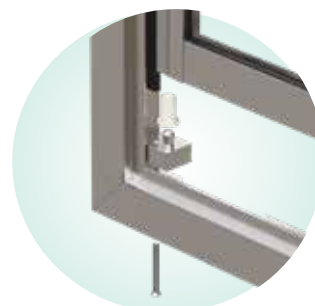

With sill

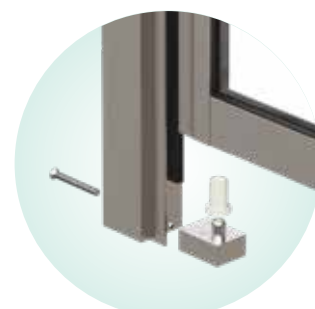

Sill-less

Custom made to order fully framed, semi-frameless and frameless shower screen kits available, discuss further with your Area Manager.

danmac.com.au

Danmac Head Office | 99 Frankston Gardens Drive Carrum Downs Vic 3201
Phone: 03 9775 1223 | Fax: 02 9775 1445
Email: danmac@danmac.com.au

Danmac Brisbane Office | Shed 3, 8-22 Jutland Street Loganlea QLD 4131
Phone: 07 3445 5100
Email: danmacbrisbane@danmac.com.au

MELBOURNE BRANCH

26-40 Pound Road West
Dandenong South VIC 3175
Phone: 03 8787 6333
Fax: 03 8787 6399
melbourne@alspec.com.au

ADELAIDE BRANCH

1 Pope Court
Beverly SA 5009
Phone: 08 8150 6960
Fax: 08 8150 6999
adelaide@alspec.com.au

PERTH BRANCH

30 Holder Way
Malaga WA 6090
Phone: 08 9209 9100
Fax: 08 9209 9199
perth@alspec.com.au

SYDNEY BRANCH

3 Alspec Place
Eastern Creek NSW 2766
Phone: 02 9834 9500
Fax: 02 9834 9532
info@alspec.com.au

NEWCASTLE BRANCH

95 Griffiths Road
Lambton NSW 2299
Phone: 02 4952 9111
Fax: 02 4952 9728
newcastle@alspec.com.au

CAIRNS BRANCH

34-38 Hargreaves Street
Edmonton QLD 4869
Phone: 07 4037 6666
Fax: 07 4037 6699
cairns@alspec.com.au

CANBERRA BRANCH

28 Sheppard Street
Hume ACT 2620
Phone: 02 5134 3300
canberra@alspec.com.au

DARWIN BRANCH

25 Bishop Street
Woolner NT 0820
Phone: 08 8941 7300
darwin@alspec.com.au

CHEVALLUM BRANCH

4-8 Empire Crescent
Chevallum QLD 4555
Phone: 07 5437 6123
Fax: 07 5437 6124
chevallum@alspec.com.au

BRENDALE BRANCH

24 Doherty Street
Brendale QLD 4500
Phone: 07 3205 9911
Fax: 07 3205 9915
brendale@alspec.com.au

TOWNSVILLE BRANCH

21 Carroll Street
Mount Louisa QLD 4814
Phone: 07 3089 4965
Fax: 1300 131 747
townsville@alspec.com.au

BUNDABERG BRANCH

17 Production Street
Svensson Heights QLD 4670
Phone: 07 4111 2000
Fax: 07 4111 2099
bundaberg@alspec.com.au

BRISBANE BRANCH

8-22 Jutland Street
Loganlea QLD 4131
Phone: 07 3089 4900
Fax: 07 3089 4999
brisbane@alspec.com.au

