

# pro-splash

AIRBORNE CONTAMINATION PROTECTION



FULLY FRAMED FIX PANELS

**alspec**<sup>®</sup>  
ALUMINIUM SYSTEMS  
SPECIALISTS

 **danmac**<sup>™</sup>  
SHOWER SCREENS AND WARDROBES

POWERED BY ALSPEC

# pro-splash



POWERED BY ALSPEC





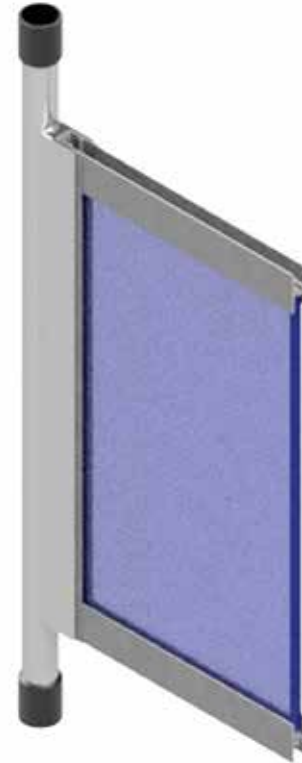



## AIRBORNE CONTAMINATION PROTECTION

The pro-splash is designed for environments where protection from coughing or sneezing and general airborne fluid contamination is of the utmost importance. Manufactured from the finest materials, the shield is virtually unbreakable serving a dual purpose of protecting against bio-hazards as well as physical threats from the public.



Top View



Code/Diagram	Description
DRC 	Return Channel (4.3m)
DSR 	Sash Rail (3.8m)
DMIST 	Mirror Stile (4.1m)
DR19 	19mm Rod (4.0m)
DUC10 	Wall Channel (4.3m)
DPR 	Pop Rivets 1,000/box
DFS1.5 	Frame Screws 6g x 1.5" SS CSK - 1,000/box
DPR1800 	Polished Rod
FSB-1 	Wall to Rod Stabilizer

