

# Opus Manufacturing Technical Page

## FHB-2-050

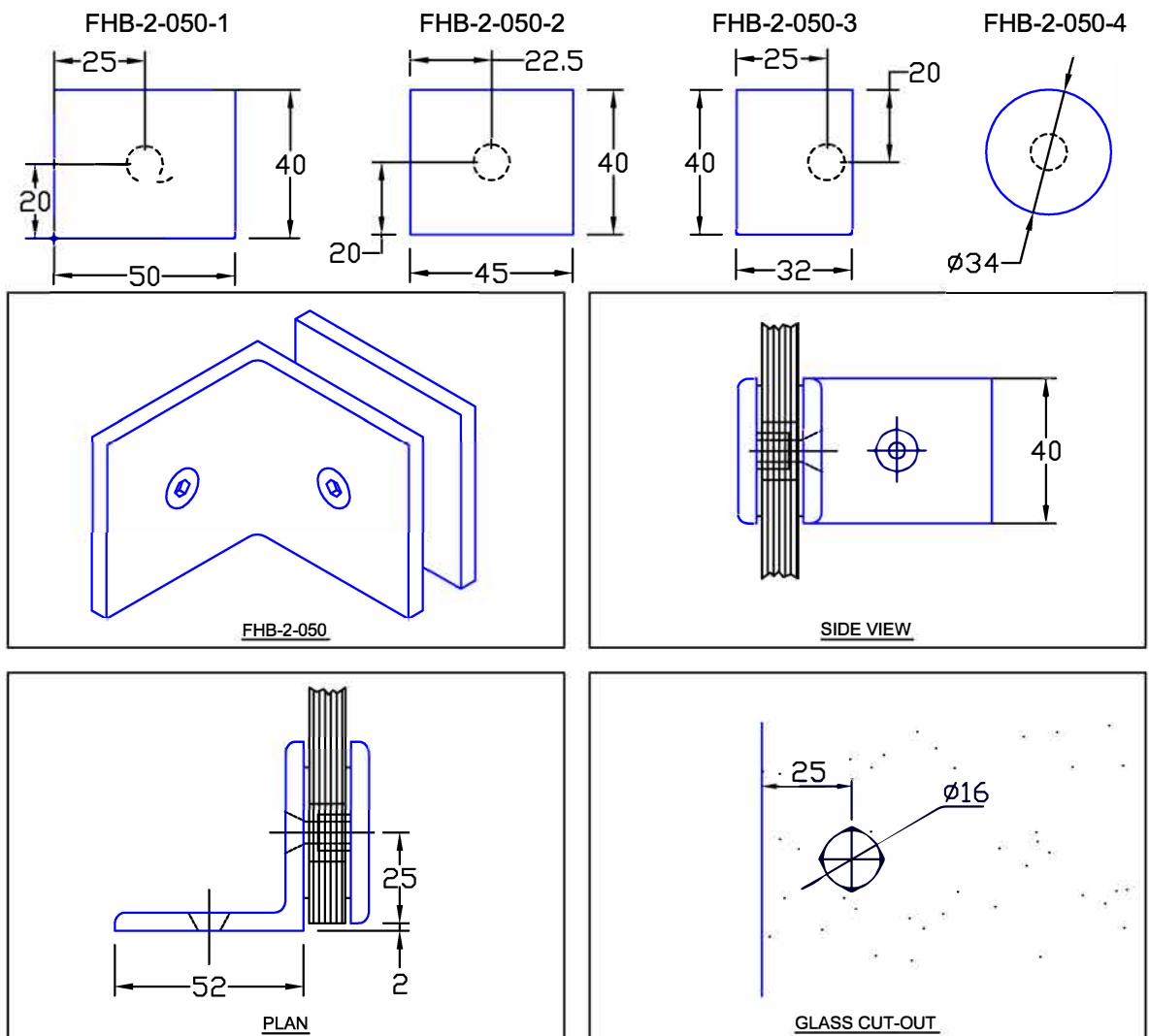

FHB-2-050 Bracket/Clamp Wall to Glass. Manufactured in solid brass, designed to secure shower enclosure glass panels to the wall or floor. FHB050-2-1,2,3,4 indicates backplate option as shown above.

Standard Finishes: Chrome; Satin Chrome; Gold.