

## Opus Manufacturing Technical Page

### NY25, HR16-192 and HSF320

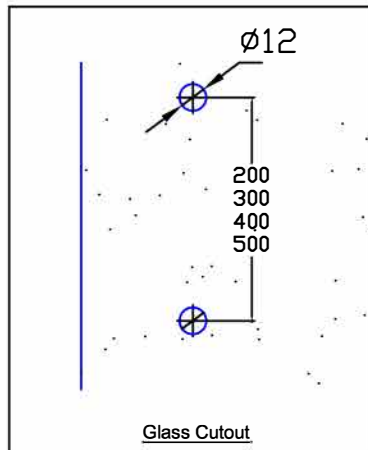

**STRAIGHT HANDLE**  
 Handles are constructed of 25mm solid stainless steel. Plastic gaskets and spacers are included to protect against glass to metal contact. A set consists of one handle for each side of the door. Specials can be manufactured.  
 Codes: NY25-300  
 NY25-400  
 NY25-500  
 NY25-600

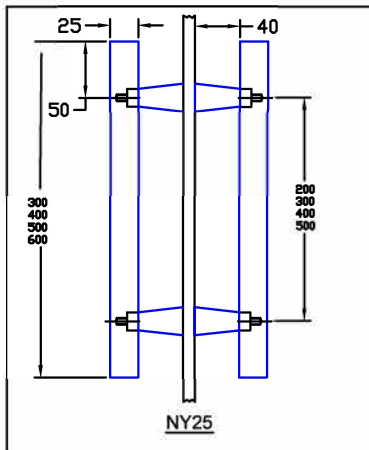
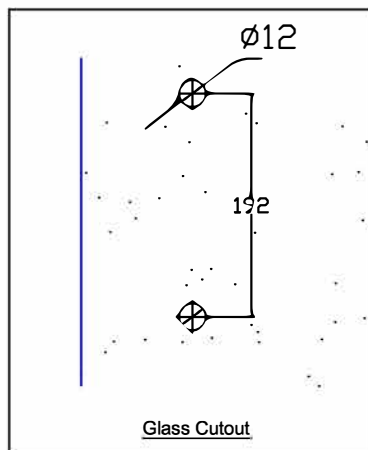
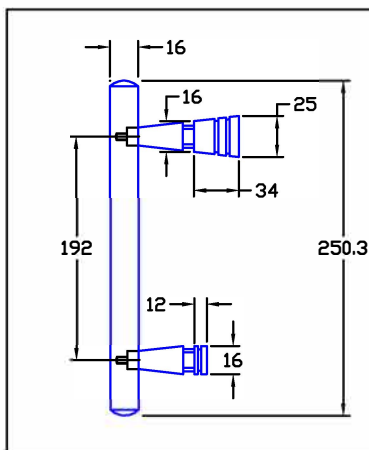

**SINGLE PULL HANDLE**  
 Made of 16mm diameter Round Bar. Plastic gasket and spacers are included to protect against glass to metal contact. A set includes a handle for one side of the door and two knobs for the other side.  
 Codes: HR16-192

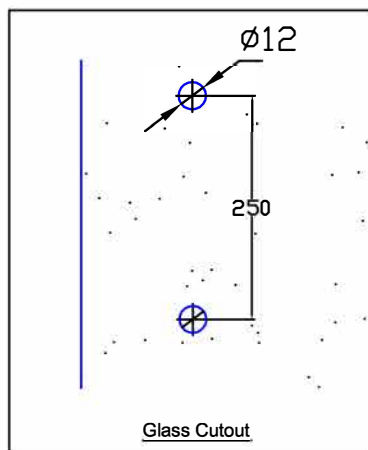
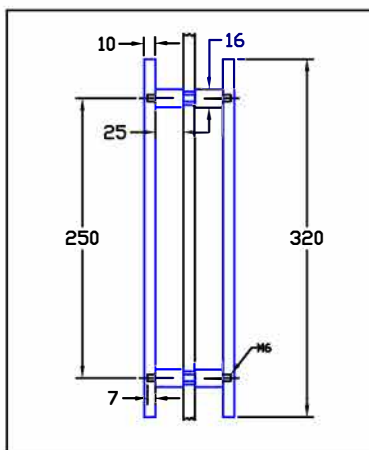

**DOUBLE PULL HANDLES**  
 Made of 20mmx10mm stainless steel flat bar. Plastic gasket and spacers are included to protect against glass to metal contact. A set includes a handle for each side of the door.  
 Codes: HSF320

Finishes: Polished Stainless Steel or Satin Stainless Steel