

Opus Manufacturing Technical Page

HBF1

Standard specifications for 6mm glass

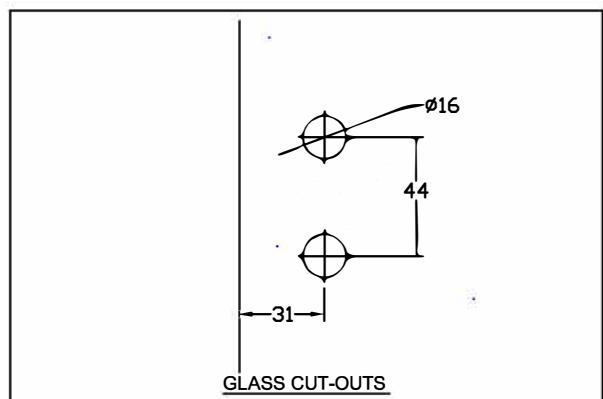
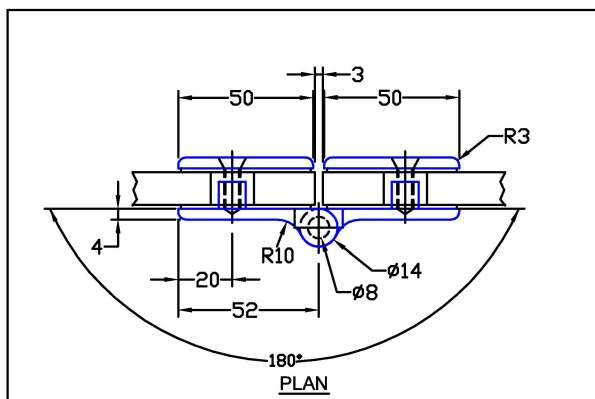
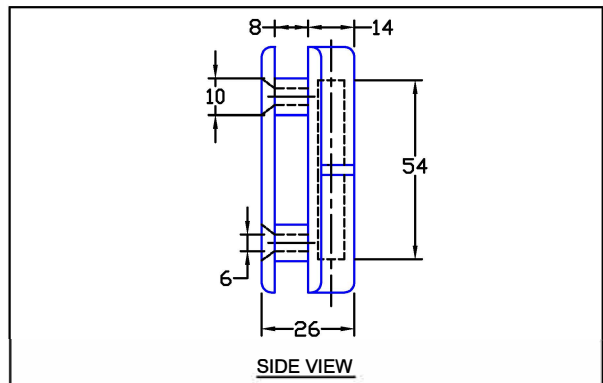
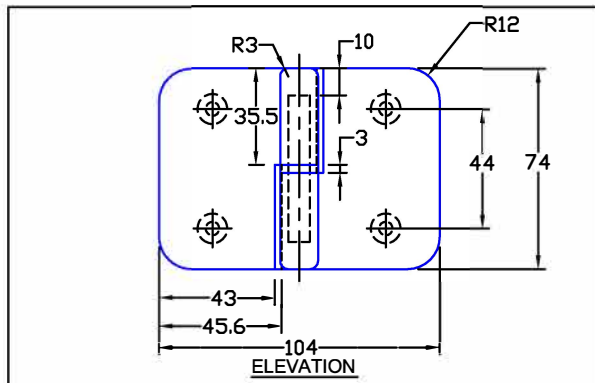
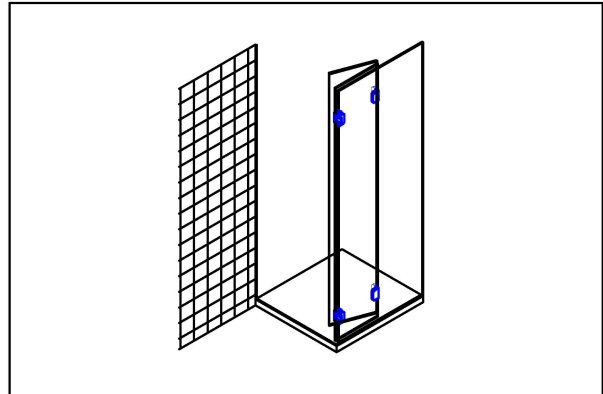
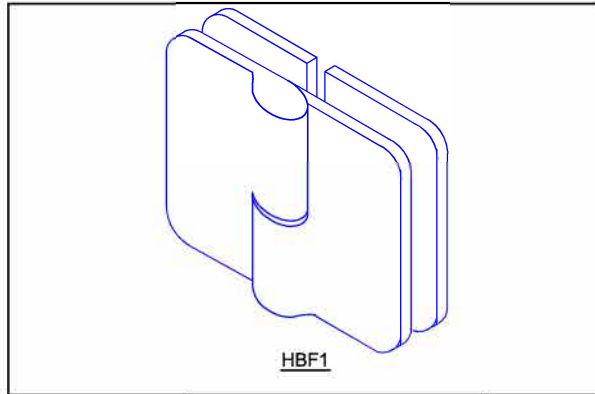

HBF1 Glass to Glass hinge to mount a door to a 6mm glass side panel. This Bi-Fold hinge has the advantage of allowing the glass to fold back on itself through a 180° angle. The hinge is secured to the panel with two holes in the glass instead of a cut-out. This results in a simpler and cheaper glass preparation. Additional advantages are better holding capabilities, and a cost effective hinge.

Hinges should be purchased and fitted as a pair enabling a top/bottom installation so that the door cannot be lifted off its hinges.

Standard Finishes: Chrome; Satin Chrome; Gold.